

Millstone making in Scotland

D Gordon Tucker*

SUMMARY

Millstones made in Scotland, especially during the 18th and 19th centuries, fell into two broad categories: those manufactured mainly from imported French burrs in urban manufactories and those made from indigenous rock at rural sites. This division applied to England as well, but there were distinctively Scottish features within each category. The urban manufacturers in Edinburgh and Glasgow usually made up their millstones from a centre-piece of indigenous rock with radial French burr segments around it, in distinction to the English method of using entirely French burr segments with a markedly random element in the pattern. The rural sites produced monolithic millstones of the type almost universally produced in English and most European quarries, suitable for the coarser grinding in ordinary mills, having a diameter of 1.1 to 1.4 m; in the far north, smaller stones, c 0.7 to 0.9 m in diameter, were made for the small horizontal or 'Norse' mills. In what was almost certainly the most important quarry of all – Kaim Hill in Ayrshire – segmented millstones were produced, a practice not established in England and not with certainty in Wales. Known urban millstone manufacturers are listed and recorded millstone quarries and other rural millstone-making sites are described. Finally some place-names in Scotland which include the word 'Millstone' are listed with the suggestion that they probably indicate the sites of early millstone making.

INTRODUCTION

As in the rest of Britain and in many other countries, millstone making in Scotland had the two divisions.

(a) The fabrication of millstones from a number (generally between eight and 28) of pieces or segments of 'French burr-stone' cemented together, bound with iron hoops, plastered over the back, and dressed flat on the front ready to take the furrows and cracking. The stone was imported from quarries at La Ferté-sous-Jouarre, some 50 km east of Paris. The fabrication was done in urban manufactories by specialist workers for whom the stone dust was a serious health hazard, leading to early death.

(b) The cutting of millstones in one piece ('monolithic' millstones) from suitable rock, sometimes quarried, often worked on the surface where it occurred, at sites widely distributed over Scotland. The complete shaping of the stone was almost always done at the quarry or place of extraction, leaving only the furrowing and cracking to be done at the mill. The industry was entirely rural.

There was in Scotland, however, another division, or partial division. This was the

* Department of Economic and Social History, University of Birmingham

fabrication of millstones from segments made at Scottish quarries, somewhat after the manner of the French burr millstones.

The fabrication of French burr millstones was a product of the demand for finer flour which arose in the 18th and 19th centuries, and the business expanded greatly during those centuries. It was brought to an end in the earlier part of the 20th century by the almost universal adoption of roller milling using steel rollers instead of millstones.

The making of monolithic millstones from indigenous rock goes back to the earliest powered mills (animal, water or wind), and, indeed, if we include hand mills, using quern-stones, for thousands of years. These monolithic stones served all grinding purposes until the 18th century, but then gradually became relegated to preliminary grinding of grain or to the grinding of fodder. Many surviving wind and water mills have both French burr stones and indigenous

TABLE 1

Urban millstone manufacturers in Scotland

EDINBURGH

MASON, Robert	2 Salamander St, Leith	c 1852
STEVENSON, Henry (‘French-Burr, Millstone & Firebrick Works’)	Duke St, Leith	c 1852
SMITH, J(oseph) & Son (‘Wireworkers and weavers, millstone builders, and importers of French burr blocks’)	219 High St	1852–78 at least, with illustrated advert ‘Established 1823’
SMITH, Son & Co (‘Wireworkers and millstone builders’)	219 High St	1889–93 at least

GLASGOW

REID, Andrew (‘French burr millstone builder’)	Delftfield Lane 145 Main St, Anderston 147 ditto	1840–7 1848 1849
REID, John (‘French burr millstone builder’)	160 ditto 9 Finnieston St 3 Havelock St	1849–58 1858–9 1859–94
NB John Reid must have died in the 1870s, but the firm carried on at 3 Havelock St		
REID, Peter (‘Brother of late John Reid’) (‘French burr millstone manufacturer’)	40 Hyde Park St also 28 Hyde Park St from 1881	1877–1907
REID, Peter & Son	310 Stobcross Street In London in the 1920s	c 1910
FLEMING, Robert (‘Millstone maker’)	Parkhouse Lane	1834–5 only
CAMERON, Dugald (previously smith & bellhanger, now also French burr m’stone mfr) (French burr millstone works, 5 Terrace St, 1859–61)	43 & 45 Bishop St, Anderston & 303 St Vincent St & 5 Terrace St	1858–61
LAING, R G (‘Millstone builder’, but possibly only merchant dealing in a wide range of goods)	29 Waterloo St	1879–91
SNOW, John	3 Havelock St (ie same address as John Reid)	1880–5
MOSSMAN, William & Co (‘Makers of granite paint rollers, millstones, & all classes of granite work for engineers’)	67 Stirling Road	1886–99
DONALD, John & Son (appears as grindstone maker, possibly not millstone maker)	42 Cadogan St	c 1889

monolithic stones; the latter were so very much cheaper than the former that it would have been uneconomic to have used French burr stones for coarse grinding. The rock used for monolithic millstones was varied; granite sometimes, limestone rarely, plain sandstone also rarely; commonest was the quartz conglomerate, a composite rock in which quartz pebbles are imbedded in a matrix of hard sandstone. The pebbles when cut to make the flat face of the millstone gave a good sharp cutting edge. A coarse grit stone like the famous Derbyshire Peak millstone grit would also be used when available.

The reason for the use of millstones fabricated from pieces or segments should, in principle, have been the difficulty of hewing the large flawless blocks needed for monolithic stones. Monolithic millstones of French burr are known, but are very rare outside France. The matter should have been purely economic, although some doubts are expressed later.

Little has been published on millstone making. My own earlier paper may be referred to for general background (Tucker 1977). Much additional information regarding millstone making in Scotland has been obtained since then, and the present paper is an attempt to give an overall view of the subject. Necessarily, however, the information must be very incomplete, and the author would be grateful for any further information which readers can offer.

Three other points should be mentioned here. First, the revival of interest in stone-ground flour on dietary grounds has led to the repair and bringing back into use of many old millstones. Second, in the later part of last century there was a considerable use of millstones called composition stones, made from emery powder or ground-up French burr moulded with some binding material into a cylindrical shape; I have not investigated whether these were manufactured in Scotland. Third, millstones were used for grinding many other materials in addition to grain, eg minerals, and monolithic stones were often used as edge-runners in these applications; an abortive attempt by John MacCulloch to exploit limestone in Skye during the Napoleonic wars, in order to make millstones for gunpowder mills, is described by Flinn (1981); but this hardly affects the discussion in this paper.

Finally, it should be made clear that by millstones I mean grinding stones used in mills driven by animal, water, or wind power; hand-querns are not regarded as millstones and are mentioned only incidentally. The normal size of millstones in the 18th and 19th centuries was from c 1.1 to 1.4 m in diameter, by c 0.3 m thick when new. However, in the far north and north-west of Scotland (especially in Shetland) there were in use until the present century numerous small water-powered corn mills of the so-called Norse type, which used millstones with a diameter in the range 0.7 to 0.9 m and with a thickness of c 0.13 m when new; these were always monolithic, and were apparently used without furrows or dressing of any kind.

(a) URBAN MILLSTONE MANUFACTURE: FRENCH BURR MILLSTONES

There are Customs records of the import of the small stone blocks known as burrs from the Continent in the first half of the 18th century, and the trade expanded greatly through the first half of the 19th. What proportion of the imports into Britain were used in Scotland is not known. Indeed, little is known of the business until the expansion of the production and publication of directories in the 19th century gave some data concerning it. This source then showed that Scotland had comparatively few specialized millstone manufacturers. Table 1 lists those which I have found, with some appropriate detail. It seems that Scotland had only two major millstone-manufacturing organizations: the Smiths of Edinburgh and the Reids of Glasgow. The other firms listed for Glasgow do not appear to be of much significance. No millstone manufacturers have been found for other Scottish towns. It is perhaps not surprising that

SCOTTISH
Wire Work & Millstone Manufactory

ESTABLISHED 1823:



J. SMITH & SON,
WIRE WORKERS AND WEAVERS, MILLSTONE BUILDERS,
AND IMPORTERS OF FRENCH BURR BLOCKS,
219, HIGH STREET, EDINBURGH.

107

S 59

ILLUS 1 Smith's advertisement from Slater's *Directory* of 1860

English-made millstones are often found in Scottish mills, especially where transport from England was easy; a good example are French burr millstones by Davies and Sned of Liverpool at the Isle of Whithorn, Wigtownshire.

Advertisements in the directories are often very informative. Illus 1 shows an advertisement by Smiths of Edinburgh for the year 1860. It indicates that their works were on the quayside (at Leith), that they made woven wire for the sieves of flour-dressing machines, and most importantly of all, that they fabricated millstones from circular or octagonal centre pieces with numerous narrow segments forming the main part of the stone. Throughout Britain as a whole, French burr millstones formed in this way are comparatively rare, but they seem to have been common in Scotland. English-made French burr millstones were mostly put together more like crazy paving, with generally four pieces forming a centre section and an almost random pattern of pieces making up the rest of the millstone, as shown by two examples in illus 2. The material here is entirely French burr, although an inferior quality may have been used for the centre pieces. Regular segmentation in English millstones, although rare, is not unknown. Gardners of Gloucester, for example, made such stones and in their advertisement in Kelly's *Directory* for 1870 showed some stones rather like Smiths', with octagonal centre-pieces but only eight segments, matching the sides of the octagon.

From numerous surviving examples of Scottish-made French burr millstones, it is known that the centre-pieces were not normally of French burr, and the purpose of the design was clearly to economize on the expensive imported French burr. The centre-piece would be made of a local grit stone, sandstone, or other suitable rock, because little of the grinding action of the millstone took place near the centre, which was usually dressed to be concave anyway. The

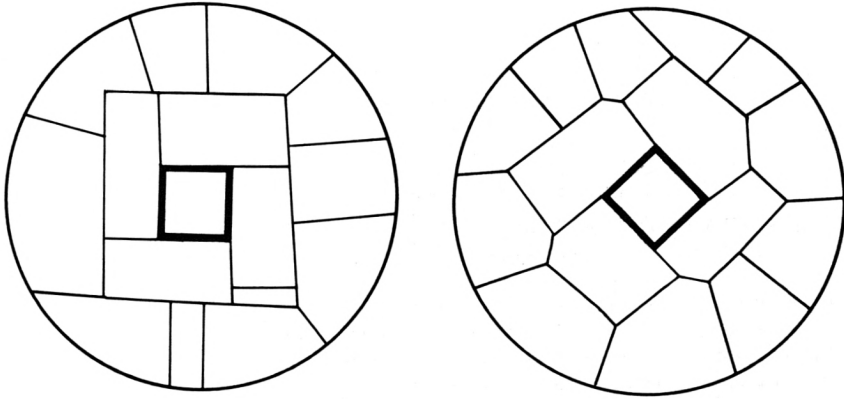

ILLUS 2 Typical patterns of French burr millstones of English manufacture

French burr could then be reserved for the outer parts where the real action occurred. Considering the obvious advantage of this system, it is surprising that it was not common practice over the whole of Britain. One Scottish example of such a stone can be seen at the mill at Old Bridge of Urr in Kirkcudbrightshire. The design of this stone is shown in illus 3, and it will be seen that there are 16 French burr segments. The eye is lined with iron, and the whole millstone is bound with three iron bands, each c 40 mm wide. An example from New Cumnock, Ayrshire, with 12 burr segments around a circular sandstone centre-piece, is shown by Hay (1976, 14, fig 5). The stones in Smiths' advertisement have 24–8 segments, by English standards an extraordinarily large number, but quite in accord with many surviving examples in Scotland. This question of the pattern of segmentation is discussed and illustrated more fully elsewhere (Tucker 1983).

Advertisements by the Reids of Glasgow, appearing in 1877–8, are shown in illus 4. They

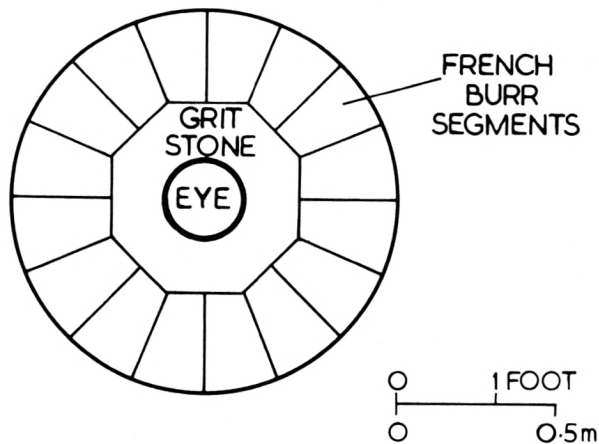

ILLUS 3 Millstone at Old Bridge of Urr Mill; French burr segments with grit stone centre

ESTABLISHED 1889.

JOHN REID,
IMPORTER AND MANUFACTURER OF
FRENCH BURR, KAIMHILL, AND DERBY PEAK
MILLSTONES,
3 HAVELOCK STREET, FINNIESTON,
GLASGOW.

MILLSTONES supplied for Grinding every description of Grain, Charcoal, Roman Cement, Bones, Coprolites, &c. Millers, Millwrights, and Merchants fitting-up Mills for Home or the Colonies, can depend on receiving an article that will give every satisfaction both in quality and workmanship, particular care being taken in selecting the qualities of stone most suitable for the purpose that they are intended for.

DERBY PEAK EDGE MILLSTONES FOR OIL MILLS.

A very Superior Stone supplied for the Shelling of Rice and Oats.

PETER REID

(Brother of the late John Reid),

French Burr Millstone Manufacturer,
40 HYDEPARK STREET,
GLASGOW,

RESPECTFULLY intimates that he has opened premises at this address for the Manufacture and Supply of all kinds of Stones for Grinding Wheat, Oats, Rice, Cement, Charcoal, Bones, Paint, Coprolites, &c., also Superior Stones for Shelling.

Millers, Millwrights, Engineers, &c., fitting up Mills at Home or Abroad, may depend upon having the best Material and Workmanship at lowest possible prices.

P. R. hopes, from his practical knowledge and personal superintendence, to merit a share of the patronage so liberally bestowed on his late Father and Brother.

Price Lists on Application.

ILLUS 4 Reids' advertisements from Glasgow *Post Office Directory* of 1877-8

published no drawings of their stones; however, surviving stones known to have been made by them are like Smiths' in having a centre-piece of local stone, although the French burr segments are fewer and wider. Their advertisements are illuminating for the listing of the many applications for which the stones may be used. It is also important to notice that John Reid lists Kaim Hill stones as one of his products. This refers to Kaim Hill in Ayrshire, which will be discussed at some length below.

Urban millstone manufactories usually consisted of large sheds with at least one long side open to the outside air. It was essential to have such ventilation to carry away the dust, as the work was done dry. Silicosis was a common disease among the workmen. The number of men would be dozens rather than hundreds.

(b) RURAL MILLSTONE MANUFACTURE: MILLSTONES MADE FROM INDIGENOUS ROCK

Although in earlier centuries millstones would have been made by local workers, probably the miller himself, out of the best available local rock, yet the requirements of a good millstone were so demanding that certain types of rock, occurring in relatively few areas, came to be known as especially suitable for millstones. For a millstone made in one piece, it was necessary to find a piece of rock at least 1.2 m square and 0.3 m thick which was free from flaws so that the millstone, when rotating in the mill, would not fly to pieces. Many monolithic millstones were fitted with shrunk-on iron bands as a safeguard against this danger, even if the stone was thought to be free from flaws. Then, of course, the rock must be hard, otherwise it could not keep its furrows and cracking sharp for reasonable periods. (NB the areas of the stone in between the furrows were known as 'lands', and these were dressed to have a rasp-like surface or 'cracking'.) The inclusion of hard quartz pebbles in the rock gave the stone a naturally good sharp grinding surface.

It seems that no Scottish rock ever became as famous for millstone-making as the millstone grit of North Derbyshire in England and the quartz/sandstone conglomerate of Monmouthshire and Anglesey in Wales. However, for a limited period around 1800, the rock from Abbey Craig on the outskirts of Stirling acquired some fame, and for much of the 19th century there was a considerable production of millstones from Kaim Hill in Ayrshire.

Information on Scottish sources of millstones is scarce. Table 2 shows the sources I have discovered from miscellaneous published material and from personal enquiry. It must be very far

TABLE 2

List of millstone quarries in Scotland (listed in descending NGR letter-square order and from south to north within each letter-square)

1	Laggan, Wigtownshire	NX 397 376
2	Glenstocking, Kirkcudbrightshire	NX 864 527
3	Burgh Muir, Edinburgh	NT 27
4	Invertiel, Fife	NT 27 89
5	Kaim Hill, Ayrshire	NS 220 530
6	Craigmaddie Muir, Stirlingshire	NS 578 763-581 762
7	Do.	NS 587 765
8	Abbey Craig, Stirlingshire	NS 814 953
9	Spittal, Stirlingshire	NS 507 973
10	Ugadale, Kintyre, Argyll	NR 782 288
11	Rhonadale, Kintyre, Argyll	NR 786 393
12	Port na Cathrach, Isle of Gigha, Argyll	NR 629 483
13	Millstone Point, Isle of Arran, Bute	NR 99 50
14	Skipness, Kintyre, Argyll	NR 883 581
15	Dunnichen, Angus	NO 50 48
16	Benheath, Perthshire	NN 90 07
17	Barrnacarry, Argyll	NM 81 22
18	Inninmore Bay, Argyll	NM 725 418
19	Gribun, Isle of Mull, Argyll	NM 349 449
20	Quarrywood Hill, Elgin, Moray	NJ 184 637
21	Aberdour, Aberdeenshire	NJ 84 65
22	Covesea, Moray	NJ 17 70
23	Shawbost, Isle of Lewis, Ross & Cromarty	NB 242 458
24	Yesnaby, Orkney	HY 23 16
25	West Burrafirth, Shetland	HU 25 57
26	Yell, Shetland	HU 48

NB The names of the counties used here are those applying in the 20th century up to the reorganization of the 1970s, and are not necessarily those in use at the time of the millstone working.

from complete. It includes some very minor and indeed insignificant sources. It is convenient to refer to all these sources as quarries, even though in some the rock was not strictly quarried, but used as it outcropped in the surface of the ground. These quarries will now be discussed individually.

1 LAGGAN, Wigtownshire

Donnachie (1971, 225–6) refers to this 'old millstone quarry' as disused before the mid-19th century.

2 GLENSTOCKING, Kirkcudbrightshire

In 1799 the *Statistical Account of Scotland* said of the parish of Colvend, in which Glenstocking Quarry lies

There is a quarry of a free or softer species of granite on one part of the shore, which is worked for millstones and from whence all the mills in the south west of Scotland are furnished. Many of them are also carried into the interior of the country and some sent to Ireland. From 15 to 20 are sold annually at about £3 each (*SAS Colvend*, 108).

In 1844, the *New Statistical Account of Scotland* said of the same parish 'There are two mill-stone quarries in the parish; but they have not been wrought of late' (*NSAS Colvend*, 217). The fortunes of the millstone-makers must have revived, for Donnachie (1971, 225–6) refers to Glenstocking as 'a famous millstone quarry dating from the late 18th century', which continued in use until the turn of the present century.

3 BURGH MUIR, Edinburgh

Fisher (1976) refers to the making of millstones here and to a complaint made in 1584 that millstones were being cut too small for the city mills; the size was thereupon fixed at 5½ ft diameter, with thickness 12 in at the eye and 10 in at the edge, and the price was to be 46s 8d.

4 INVERTIEL, Fife

It has been stated (Shaw 1979, 178) that 'local substitutes' for French burrs were made here during the Napoleonic Wars. Earlier, the rock was reported to be 'of the nature of the Derbyshire Marble, but so hard that they make Millstones chiefly of one bed of it . . .' (Pococke 1760, 281).

5 KAIM HILL, Ayrshire

This was probably the most important source of millstones in Scotland. It lies c 1 mile SE of Fairlie, but is in the parish of West Kilbride. The industry here appears to be poorly documented, not being mentioned in any of the three *Statistical Accounts of Scotland*, although there are a few useful passing comments in some other works, which are referred to below. The field evidence, however, is quite informative; many walkers must have noticed the area of waste rock on the south-western slope of the hill (NGR NS 220 530) extending perhaps 300 m from N to S and 100 m from W to E. Among all this waste there are a few pieces of rock which are recognizably parts of millstones, and which tell us what kinds of millstones were made. The rock is a quartz/sandstone conglomerate which appears to be very similar to that used for the well-known Welsh millstones made around Penallt in Monmouthshire (Tucker 1971) and in Angelsey (Tucker 1980). It is probably not quite the same, however, as it is described as 'Brecciated Sandstone in the Millstone Grit formation' (Hunt 1858).

Millstone making at Kaim Hill must have been active in the 18th century, for by 1805 it was well-known, its products going as far afield as Ireland, America and the West Indies (Forsyth 1805, 470); and Aiton (1811) stated that the corn mills for 50 miles around had 'long been provided with this species of mill-stone'. No doubt the work continued through the first half of the 19th century; millstones were certainly being produced in 1851 (Anon 1877, 169), and were recorded in Hunt's *Mineral Statistics* in 1858. We have seen in illus 4 that John Reid of Glasgow was advertising Kaim Hill millstones in 1877–8, and in fact he had been doing so in 1869–70. In 1899, Lamb (1899, 50–1), stated 'The making of millstones from Kaim Hill Conglomerate is still carried on, on a reduced scale. . . . The introduction of steel rollers for grinding purposes has greatly diminished the demand for them'. The industry probably did not survive long into the present century. In 1953 it was written that

KAIM HILL MILLSTONE PATTERNS

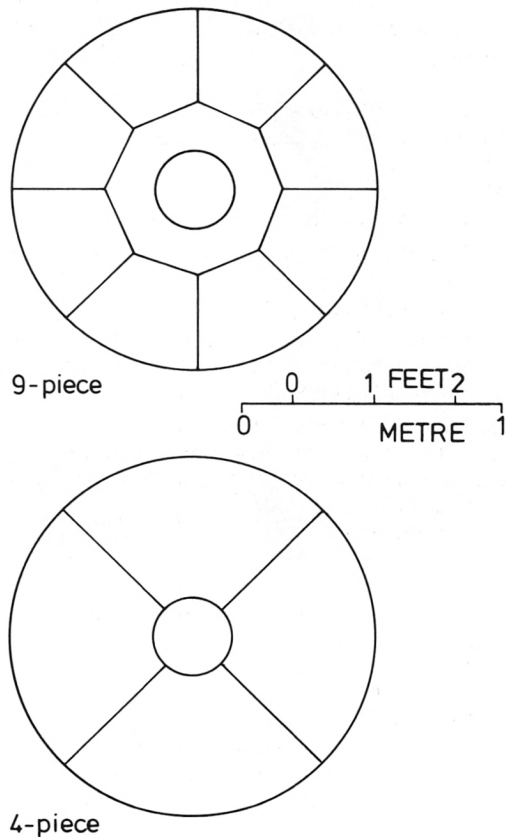

ILLUS 5 Kaim Hill millstone patterns

An industry of Fairlie's past was the manufacture at Fencebay, one and a half miles south of Fairlie, of millstones. The stone, quarried from Kaim Hill, was specially suitable for this purpose, and until modern milling methods superseded the use of millstones the Fairlie product was sent all over Britain and exported to markets as distant as Australia (Lang 1953, 213).

This statement introduces a matter of some interest, namely, that there was a works of some kind at Fencebay. The field evidence on Kaim Hill suggests that the stone cutting and shaping was done there, on the open hillside; it is therefore most likely that the works at Fencebay (which may well have been opened at a comparatively late stage of the industry's history) was concerned with the fitting of iron bands and possibly the cutting of furrows and preliminary dressing.

Turning to the field evidence on Kaim Hill, pieces of shaped stone indicate clearly that three kinds of millstone (at least) were made; monolithic, nine-piece and four-piece. The design of the two latter types is shown in illus 5. Typical field evidence is shown in illus 6-10. Illus 6 shows one part of a monolithic millstone which has been broken into two; the other part lies just outside the photograph. The diameter is 1.22 m; the eye hole has been cut 0.13 m deep, and the stone evidently broke (or was found to have a flaw) and was abandoned before being turned over to have the other side finished.

Illus 7 shows two of the segments which, together with the octagonal centre-piece shown in different stages of cutting (illus 8 & 9), make up the nine-piece type of millstone shown in the drawing



ILLUS 6 Half a monolithic millstone at Kaim Hill (white bar is 0.3 m long)

in illus 5. Illus 10 shows one quarter-section of a four-piece millstone as indicated in illus 5. It is felt that this field evidence is very convincing. The nine-piece and four-piece millstones would need to be cemented together and bound with iron bands. This part of the process of manufacture may well have been done at Fencebay, although there are the remains of a building on Kaim Hill, at the edge of the working area, which might also, at some period, have been a smithy. It will now be of interest to note

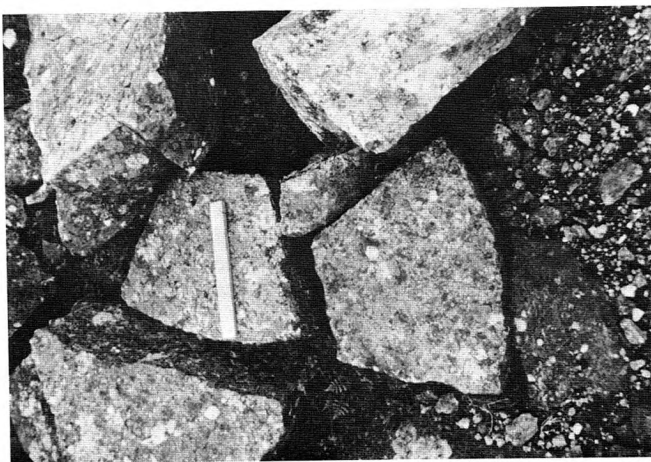

ILLUS 7 Two segments of a nine-piece millstone at Kaim Hill (white bar is 0.3 m long)

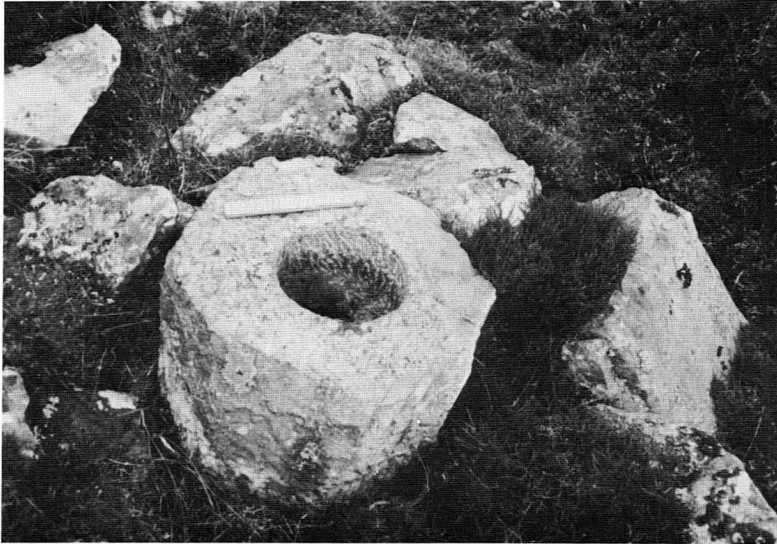

ILLUS 8 Octagonal centre-piece of millstone at Kaim Hill, with eye partially cut (white bar is 0.3 m long)

Lamb's comment of 1899 'They are generally made in six or eight pieces, bound together with Roman cement round a central stone, the whole being firmly welded together with iron hoops' (Lamb 1899, 50-1). I found no hexagonal centre-pieces or 60-degree segments, so have no field evidence to support Lamb's statement regarding six pieces round a central stone; but there is no reason to doubt it.



ILLUS 9 Octagonal centre-piece of millstone at Kaim Hill, in a less advanced state than that in illus 8 (white bar is 0.3 m long)



ILLUS 10 Quarter-section of four-piece millstone at Kaim Hill (white bar is 0.3 m long)

6 & 7 CRAIGMADDIE MUIR, Stirlingshire

These interesting workings escaped notice in the various *Statistical Accounts of Scotland* (parish of Baldernock), so probably date from before the middle of the 18th century or were perhaps not of much commercial importance. They have been recorded by the Royal Commission on the Ancient and Historical Monuments of Scotland, who give an excellent account of the method of manufacture as deduced from the evidence at the first site

Millstones in different stages of completion and of various dimensions can be seen here and there on the exposed surface of the rock. The earliest stage . . . is exemplified by rings pecked out on the flat surfaces of suitable expanses of rock. Measuring about 2 in in width and half an inch in depth, they vary in diameter from 6 ft 6 in to 5 ft. A later stage in the process, also to be seen here, is the cutting of a channel some 6 in to 9 in wide, along and on the outer side of the pecked ring; this provided the space in which the quarryman could define and roughly dress the outer edge of the millstone, deepening the channel to give it the required thickness. At this stage, which is also represented, the millstone was complete except for being freed from the living rock beneath, but it seems that the central hole was made before this final operation was carried out (RCAMS 1963, 443–4).

I am surprised that the RCAMS consider that the rock outcrop is lava; it seems to me to be essentially similar to the quartz/sandstone conglomerate so commonly used for millstones, which is a sedimentary rock.

As regards the second site, the rock here is a kind of grit stone, without the large pebbles of the conglomerate. The RCAMS say that the millstones here are 4 ft (1.22 m) in diameter (*ibid*), and certainly I found one barely-started stone of this size, and several hollows from which stones of this size had evidently been extracted. However, one only partially cut stone (illus 11), was 1.42 m in diameter and the method of formation was rather different, the millstone being cut from a projecting rock of convenient form. Another interesting find on this site was a broken quern-stone, 0.6 m in diameter, with a hole of 0.15 m diameter cut to a depth of only c 0.08 m. It was c 0.25 m thick, and apparently not attached to parent rock.



ILLUS 11 Partially cut millstone on Craigmaddie Muir (second site), 1.42 m in diameter (white bar is 0.3 m long)

It is obviously difficult to draw useful general conclusions about millstone making on Craigmaddie Muir. There was a considerable amount of working, but it may well have been spread over such a long period that its intensity would have been too low for it to be described as an industry. It seems unlikely that there was any working in the 19th century.

8 ABBEY CRAIG, Stirlingshire

This quarry, in the parish of Logie, just on the east side of the town of Stirling, was essentially a quarry for building stone, but for a few years at the end of the 18th and beginning of the 19th centuries it acquired a fame and importance as a source of rock for millstones. This arose because the French wars of that period made it very difficult and expensive to obtain French burr millstones, and the Society for the Encouragement of the Arts, Manufactures and Commerce (a London-based organization) offered a prize of £105 to any person who could discover a source of rock in Britain which would enable millstones to be made which would be judged as good as French burrs. James Brownhill, the miller of the Alloa Mill Company, thought that the rock from Abbey Craig, on account of its rough surface when broken, would make good millstones, and had a pair fabricated in the manner of French burrs. Each millstone weighed c 1.4 tonnes, and the bedstone was made of six pieces while the runner had 14; the diameter was 1.37 m, and the thickness was 0.33 m at the eye and 0.28 m at the rim. The performance of this pair in grinding wheat was certified to be as good as that of French burrs; others were made and a pair sent to London. A prize was duly awarded to James Brownhill (Anon 1802). It was later stated that over 300 pairs were made and sold widely, at prices in the range £12 to £20. During the French wars, the price of a pair of French burr millstones had risen to as much as £60, so the demand for Abbey Craig stones was understandable. After the war, as the price of French stones fell, so the demand for Abbey Craig stones fell, and eventually disappeared (NSAS Logie, 223). This must surely indicate that the quality of Abbey Craig stones was not equivalent to that of the French burrs.

The rock at Abbey Craig has been variously described as columnar basalt or whin-stone; it is an

igneous rock. The very large quarry has been worked for building stone since the millstone era, and has more recently been used as a dump for old road metal, etc; it is also very overgrown. There is therefore little prospect of finding any field evidence of millstone making. One thing which is not clear is why the millstones were made from pieces in the manner of French burrs. It could be that the rock could not be wrought in sufficiently large pieces to enable monolithic millstones to be made; or it might have been thought that there was merit in copying the style of the French stones. The first maker of the millstones employed by Brownhill was a John Burns, who was by trade a maker of French burr millstones (Anon 1802); perhaps he knew no other way of making millstones.

9 SPITAL, Stirlingshire

This is a very minor working, in which there is evidence of two millstones of about 1.5 m in diameter having been cut from the conglomerate (RCAMS 1963, 443-4).

10 UGADALE, Kintyre, Argyll

This was a very minor and probably ancient millstone working (RCAMS 1971, 209).

11 RHONADALE, Kintyre, Argyll

Another very minor, but probably 18th or 19th-century millstone working (*ibid*).

12 PORT NA CATHRACH, Isle of Gigha, Argyll

A number of small millstone workings are said to exist in this area, and a particular one recorded by RCAMS displayed the technique 'of excavating a deep peripheral groove in a suitably inclined rock-face, and thereafter cutting along the bedding-plane to free a section of the required thickness' (*ibid*). This millstone, which had been abandoned because of a fault, was to have been of 1.5 m in diameter, and was therefore dated to the 18th century or later.

13 MILLSTONE POINT, Isle of Arran

The name here is in itself suggestive, but the former making of millstones is put beyond doubt by a photograph and description sent to me by Dr C A Whatley. There is evidence of a good deal of stone working in this remote place, but it is most unlikely that any of it was done for other than local use.

14 SKIPNESS, Kintyre, Argyll

Again, a very minor working, probably ancient (RCAMS 1971, 209).

15 DUNNICHEN, Angus

This source of millstones was given by Hunt (1858). He entered it in his list as 'Castle Quarry, Forfarshire, nearest station Dunnichen; rock, Old Red Sandstone; purpose, Millstones'. Presumably Castle Quarry was on Castle Hill at Dunnichen, national grid reference of summit NO 507 487 and was not the large Craig Head Quarry shown on OS maps at NO 510 478.

16 BENHEATH, Perthshire

This source of millstones was given by Hunt (*ibid*); he stated that they were made from old Red Sandstone by James Mailler. As Benheath is in the parish of Blackford, this is presumably the quarry referred to under this parish in the *Statistical Account* of 1792, thus:

The stone in this parish is of a very hard quality. There is a large quarry in Abercairney's lands, at the foot of the Ochils, which for many years furnished fine mill-stones to all the mills many miles round; it is still working, though the demand for mill-stones is not now so great as formerly (SAS Blackford, 206).

Curiously, in view of Hunt's entry for 1858, there is no mention of millstone making in this parish in the *New Statistical Account* of 1837.

17 BARRNACARRY, Argyll

An old quarry in the coarse conglomerate shows signs of considerable millstone working, the millstones being detached from the parent rock by wedges. A number of partially detached millstones remain *in situ*, with diameters of 1.0 to 1.2 m (RCAMS 1974, 277).

18 INNINMORE BAY, Argyll

At this site, on the north shore of the Sound of Mull, a bed of coarse-grained sandstone outcrops immediately above high-water level and is reported by the RCAMS to have evidently served 'as a source both for millstones and tombstones. Several scars made by millstone-quarrying can be seen in the exposed rock-face, together with a number of unfinished millstones. . . . Stone was evidently transported directly from the site by sea' (RCAMS 1980, 250).

19 GRIBUN, Isle of Mull, Argyll

Mr T Astbury sent me a photograph of a partly-cut millstone c 1.25 m in diameter, still attached to the parent rock, on Rubha-baile na h'Airde at Gribun. The material was pebbly grit stone and Macnab (1970, 194) describes millstone-making here as 'a small industry' producing 20 or 30 millstones annually at some unspecified period. As the quarry was just above high-water mark, the stones could be readily transported by boat.

20 QUARRYWOOD HILL, Elgin, Moray

This is in the parish of New Spynie. In 1835 the NSAS reported

There is, near the summit of Quarrywood-hill, a free-stone quarry, very hard and durable, which supplies a large extent of country with mill-stones, and the town of Elgin and neighbourhood with stones for building (NSAS New Spynie, 98).

Hunt (1858) described the rock as Old Red Sandstone, and the purpose of the quarry as 'Millstones, and for building'. The OS maps show a very large number of quarries on Quarrywood Hill. The Geological Survey (Peacock *et al* 1968, 57, 73-5) says that the Old Millstone Quarry is at 390 ft (119 m), and 500 yards (c 460 m) ENE of the hill-top. This is probably the one at NGR NJ 184 637.

21 ABERDOUR, Aberdeenshire

Both the SAS and NSAS describe commercial millstone making from the coastal rocks of this parish. The main quarry, employing at one time 12 workmen (SAS Aberdour, 587), but by 1845 only 'four or five . . . who can scarcely earn a livelihood' (NSAS Aberdour, 269), was near Pennan (NJ 84 65); there had once been another two or three miles to the east. The Pennan quarry was probably the one referred to by Hunt (1858) as Gardenstown, Banffshire, nearest port Gamrie; this quarry was almost certainly within a few hundred metres of the boundary of Gamrie parish, and no other reference can be found to millstone making in Gardenstown or Gamrie.

22 COVESEA, Moray

Mr I A G Shepherd has informed me that millstones were made from the sandstone in the sea cliffs here and that there is a partially-worked stone *in situ* in the tidal zone.

23 SHAWBOST, Isle of Lewis, Ross & Cromarty

Mrs Frances Murray reported (via Mr Astbury) a small millstone quarry here near the Shawbost Norse-type watermill.

24 YESNABY, Orkney

My only reference for this is the statement by MacGregor (1940, 30) that the Old Red Sandstone at Yescanaby (an alternative spelling for Yesnaby) was used for millstones. There are several disused small quarries marked on the OS maps; the nearest is at HY 230 166.

25 WEST BURRAFIRTH, Shetland

26 YELL, Shetland

MacGregor (*ibid*) says that garnetiferous schists were used for millstones in both these places.

The 26 millstone-making sites discussed above cannot possibly represent a complete list for Scotland, although it may include all those of any significance in terms of commerce or the history of technology. Only some half-dozen come into this class and only Kaim Hill and Abbey Craig

seem to have been of real importance. It is interesting that both of these made millstones of the fabricated (ie built up from segments) class rather than the monolithic type (although the latter is represented in the field remains at Kaim Hill). I know of no case of this among the much larger English millstone quarrying activity. There are two instances of its being reported from Wales. One was in a statement by Heath (1803) regarding millstone making at Penallt, Monmouthshire. Heath was writing in 1803 at the time of the French wars and said 'Very excellent mill-stones are cut in dove-tailed burrs, and many millers pronounce them equal to the valuable French stones'. The other instance was a successful entry for the prize offered by the Society for the Encouragement of Arts, Manufactures and Commerce. It was made in 1799 by Richard Bowes of Conway in Caernarvonshire, using a local rock (Anon 1800). No field evidence has been reported in support of either of these. As I know of none for the Abbey Craig stones, this leaves Kaim Hill as the only British instance where field evidence has been found of fabricated construction from indigenous rock, and where this system is believed to have been used for a large part (if not all) of the 19th century.

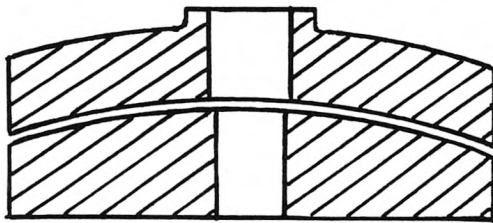

ILLUS 12 Cross-section of a pair of Shetland millstones
(diameter generally in range 0.68–0.91 m)

The last four millstone quarries (23–26) in the list are in areas where the main use of millstones was in the small 'Norse' type of watermill, where a small horizontal water wheel or 'tirl' directly drives the upper millstone which is supported on the vertical axle of the wheel. Such mills were, and their remains still are, particularly common in Shetland. The standard reference work seems to be Goudie (1886). The millstones were much smaller than those used in the ordinary kind of mill. Both Mr John Hume and Mr John Bedington have separately given me photographs and dimensions of numerous surviving Shetland millstones, and for about 50 specimens the diameter averages c 0.81 m, with a range from 0.68 to 0.91 m. Thickness is typically c 0.13 m. The stones usually have a concave runner (ie upper stone) and convex bedstone as shown in illus 12. As there are apparently no furrows or other dressing on the grinding surfaces, this curved surface arrangement is no doubt necessary to help the meal pass out through the stones. Raised flanges around the eye were occasionally found as also shown in illus 12. As these stones did not have to carry a dressing, the choice of rock might well have been less critical than in the ordinary millstones. Certainly the specimens observed used several different kinds of rock (even within Shetland), from sandstone to a sort of highly-micaceous granite with small red pebbles – presumably the garnetiferous schist reported by MacGregor (1940, 30) and even one pair of concrete stones! The quarries Nos 25 and 26 evidently represent only part of Shetland's supply of millstones. However, Mr Graham Douglas informs me that most mills in Orkney appear to use the stone from Yesnaby (no 24). In 1822, Hibbert (quoted by Bennett & Elton 1899, 19) described the Shetland millstones as 'commonly formed of a micaceous gneiss'.

TABLE 3

Place-names in Scotland with the word 'millstone'

1	<i>Millstone Edge</i> , Roxburghshire	NT 43 00	Hill of 565 m
2	<i>Millstone Rig</i> , Peebleshire	NT 08 54	Hill of 439 m
3	<i>Mill Stone Neuk</i> , East Lothian	NT 70 78	Rocky coast
4	<i>Millstone Rock</i> , Fife	NT 00 85	Rocky coast
5	<i>Millstone Rig</i> , Lanarkshire	NS 68 33	Hill of 370 m
6	<i>Millstone Wood</i> , Stirlingshire	NS 56 86	On rising ground on moor
7	<i>Millstone Point</i> , Arran	NR 99 50	Remote rocky coast
8	<i>Millstone Wood</i> , Fife	NO 43 16	On rising ground above R Eden
9	<i>Millstone Hill</i> , Aberdeenshire	NJ 67 20	Hill of 408 m
10	<i>Millstone Hill</i> , Banffshire	NJ 42 57	Hill of 301 m
Note also:			
11	<i>Grindstone Rig</i> , Ayrshire/Lanarkshire border	NS 72 23	Hill of 483 m

We turn now from fact to speculation. It has already been noted above that millstones were made at Millstone Point in the Isle of Arran. There are other places in Scotland (many are hills of considerable elevation) which have the word 'Millstone' in their names. Table 3 lists a total of 10 such places (including Millstone Point in Arran) which are all named on at least one of the OS maps. Grid references are given to only four figures as diffuse areas are involved. There is also listed one hill with 'Grindstone' in its name. On the face of it, it would seem probable that at some period millstones were made at each of these places. There are similar place-names in England (eg the famous Millstone Edge in Derbyshire, NGR SK 24 80, where millstones were made in large quantities until the present century) and some a little different, such as Millstone Hole (NGR SK 26 86) and Millstone Car (NGR SK 29 79), but it is not proven that all indicate the making of millstones. The geological maps for Scotland, so far as I can interpret them, do not show most of these sites as very promising for millstone making: few have millstone grit or conglomerate, although the one proven case – Millstone Point in Arran – does have a sort of millstone grit, described as 'pebbly grit' by Tyrrell (1928). But other materials, such as granite, have been used for millstones, and in days when transport was difficult the best use would have been made of local resources even when they were far from ideal.

There are probably also many places with the Gaelic equivalent of 'millstone' (ie clach-mhuilinn) in their names. One example, drawn to my attention by Mr I Fisher, is Cnoc na Cloiche-muilinn, at NGR NR 36 47, just behind Port Ellen on Islay, Argyll.

ACKNOWLEDGEMENTS

I am very grateful to Dr C A Whatley of the University of Dundee; to Messrs G D Hay, J G Dunbar, I Fisher and G Stell of the Royal Commission on the Ancient and Historical Monuments of Scotland; to Mr John Hume and Mr Graham Douglas of the University of Strathclyde; to Mr Tom Astbury and Mrs Frances Murray of the Falkirk Museum; to Dr H S Torrens of Keele; to Mr I A G Shepherd of Aberdeen, and to Mr John Bedington of Birmingham, for various information and photographs which have been most helpful in the preparation of this paper. I am also grateful for the use of the facilities of the Mitchell Library, Glasgow and the Central Library, Edinburgh, and for the assistance of my wife, Mary, in the field as well as in the library work. The map and geological libraries of the University of Birmingham have been invaluable.

REFERENCES

- Aiton, W 1811 *General view of the agriculture of the County of Ayr*. Glasgow.
- Anon 1800 *Trans Soc for Encouragement of the Arts, Manufactures and Commerce*, 18 (1800), 197.
- Anon 1802 *Trans Soc for Encouragement of the Arts, Manufactures and Commerce*, 20 (1802), 271–5.
- Anon 1877 'The geology of millstone grit', *The Miller*, (4 June, 1877), 169.
- Bennett, R & Elton, J 1899 *Watermills and windmills*, vol 2. London.
- Donnachie, I 1971 *Industrial archaeology of Galloway*. Newton Abbot.
- Fisher, I 1976 'Building-stone and slate: some regional aspects of Scottish quarrying', in Scottish Vernacular Buildings Working Group, *Building construction in Scotland*, Edinburgh & Dundee, 16–27.
- Flinn, D 1981 'John MacCulloch, MD, FRS, and his geological map of Scotland: his years in the Ordnance, 1795–1826', *Notes Rec Roy Soc*, 36 (1981), 83–6.
- Forsyth, W 1805 *Beauties of Scotland*.
- Hay, G D 1976 'Work of the Royal Commission and the National Monuments Record in the field of industrial archaeology', *Scot Archaeol Forum*, 8 (1976), 1–15.
- Heath, C 1803 *Historical and descriptive account of . . . Tintern Abbey*. Monmouth.
- Hunt, R 1858 *Mineral statistics*. London.
- Goudie, G 1886 'On the horizontal water-mills of Shetland', *Proc Soc Antiq Scot*, 8 (1885–6), 257–97.
- Lamb, J 1899 *West Kilbride and neighbourhood*. Ardrossan.
- Lang, T (ed) 1953 *Glasgow, Kyle and Galloway*. London.
- MacGregor, M 1940 *Synopsis of the mineral resources of Scotland*. Edinburgh.
- Macnab, P A 1970 *The Isle of Mull*. Newton Abbot.
- NSAS Aberdour *The New Statistical Account of Scotland*, vol XII, Aberdeen, Parish of Aberdour, 1845.
- NSAS Colvend *The New Statistical Account of Scotland*, vol IV, Kirkcudbright, Parish of Colvend & Southwick, 1845.
- NSAS Logie *The New Statistical Account of Scotland*, vol VIII, Stirling, Parish of Logie, 1845.
- NSAS New Spynie *The New Statistical Account of Scotland*, vol XIII, Elgin, Parish of New Spynie, 1845.
- Peacock, J D *et al* 1968 *Geology of the Elgin district*. Edinburgh.
- Pococke, R 1760 *Tours in Scotland, 1747, 1750, 1760*. (= *Scot Hist Soc*, 1 (1887)).
- RCAMS 1963 Royal Commission on the Ancient and Historical Monuments of Scotland, *Stirlingshire: an inventory of the ancient monuments*, vol 2. Edinburgh.
- RCAMS 1971 Royal Commission on the Ancient and Historical Monuments of Scotland, *Argyll: an inventory of the ancient monuments*, vol 1, Kintyre. Edinburgh.
- RCAMS 1974 Royal Commission on the Ancient and Historical Monuments of Scotland, *Argyll: an inventory of the ancient monuments*, vol 2, Lorn. Edinburgh.
- RCAMS 1974 Royal Commission on the Ancient and Historical Monuments of Scotland, *Argyll: an inventory of the ancient monuments*, vol 3, Mull, Tiree, Coll and North Argyll. Edinburgh.
- Shaw, J P 1979 *The utilisation of water power in Scotland 1550–1750*. PhD Thesis, University of Edinburgh.
- SAS Aberdour *The Statistical Account of Scotland*, Sinclair, Sir J (ed), vol XII, 1794, Parish of Aberdour.
- SAS Blackford *The Statistical Account of Scotland*, Sinclair, Sir J (ed), vol III, 1792, Parish of Blackford.
- SAS Colvend *The Statistical Account of Scotland*, Sinclair, Sir J (ed), vol XVII, 1796, Parish of Colvend & Southwick.
- Tucker, D G 1971 'Millstone making at Penallt, Monmouthshire', *Ind Archaeol*, 8 (1971), 229–39, pls on 321–4.
- Tucker, D G 1977 'Millstones, quarries, and millstone-makers', *Post-Medieval Archaeol*, 11 (1977), 1–21.
- Tucker, D G 1980 'Millstone making in Anglesey', *Wind and Water Mills*, 1 (1980), 16–23.
- Tucker, D G 1983 'Millstones north and south of the Scottish border', *Ind Archaeol Rev*, 6 (1982) (1983), 186–93.
- Tyrrell, G W 1928 *The Geology of Arran*. Edinburgh.